

Keyboard System WB24

Compact 24 Key Keypad

Sealed to IP 65

**Matrix version or free programmable
with PS2/USB Interface**



DS Keyboard System WB 24

The advantages are:

- excellent tactile feel
- Latch together parts for easy of Assembly
- Very rugged construction for Hostile Enviroments
- Dust and Splashproof IP 65
- Key Inscription laser marked or double-shot moulded keytops
- Click - On Key for easy Inscription with paper insert

Technical Data:

- Keytravel 2,0mm mit 0,3mm Overtravel
- Actuation force 2,0 N
- Durability 1 million Operations
- Contact load < 30V 5mA
- Dimensions outside 103 x 78,8mm
Assembly plate 1,5mm necessary!

Force Way Diagram

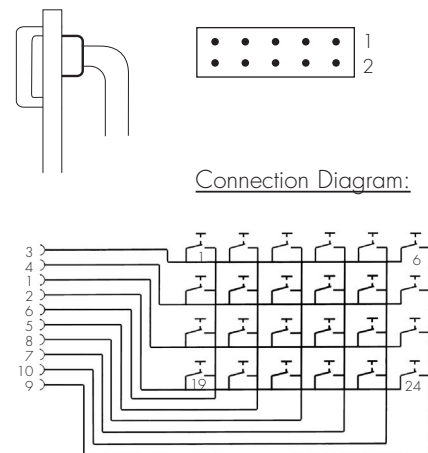
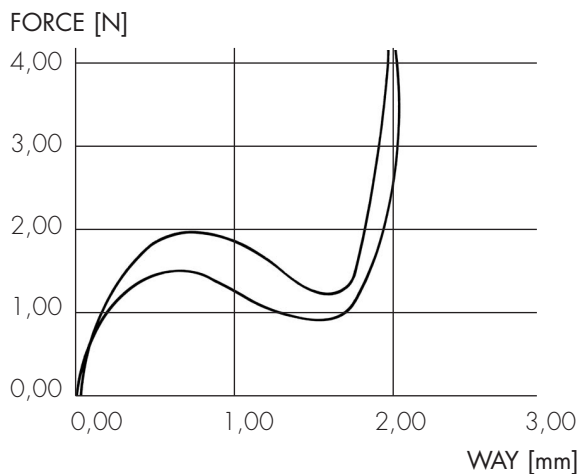

Keyboard System WB 24 EL

Design as described for WB 24 but with freely programmable Electronics PS2 or USB compatible. Easy programming with Help of DS Teach Software.

Connecting Cable allocation according to interface

(cabels are soldered on Keyboard-Side, optional plug connections possible on request)

AT
5-polig
DIN

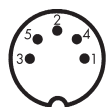

PIN	Signal
1	Clock/Tastatur
2	Data / Tastatur
3	N.C.
4	GND/Tastatur
5	+5V/ Tastatur

PS2
6-polig
MiniDIN



PIN	Signal
1	Daten/Tastatur
2	N.C.
3	GND
4	+5V
5	Clock/Tastatur
6	N.C.

USB



PIN	Signal
1	V+
2	D-
3	D+
4	GND

Cutout for
appliance frontpanel

