

# Connection of units and cable lengths to Vital 1

## Three connection alternatives

According to Category 4 (EN-954-1) connection of sensors/adaptor units in the Vital safety circuit **must be made as per the following connection examples.**

### Example 1

Use separate connection cables from each sensor/adaptor unit to the Vital safety module. Interconnections to be made via suitable terminations in the control cabinet.

### Example 2

Use Tina4A/Tina8A connector blocks to simplify connection of externally mounted sensors/adaptor units. Only Tina4A/Tina8A connector blocks must be used. **Use of any other connector blocks will not meet the safety circuit requirements.**

### Example 3

Use M12-3A and M12-3B 'Y' connectors to connect sensors in series/parallel.

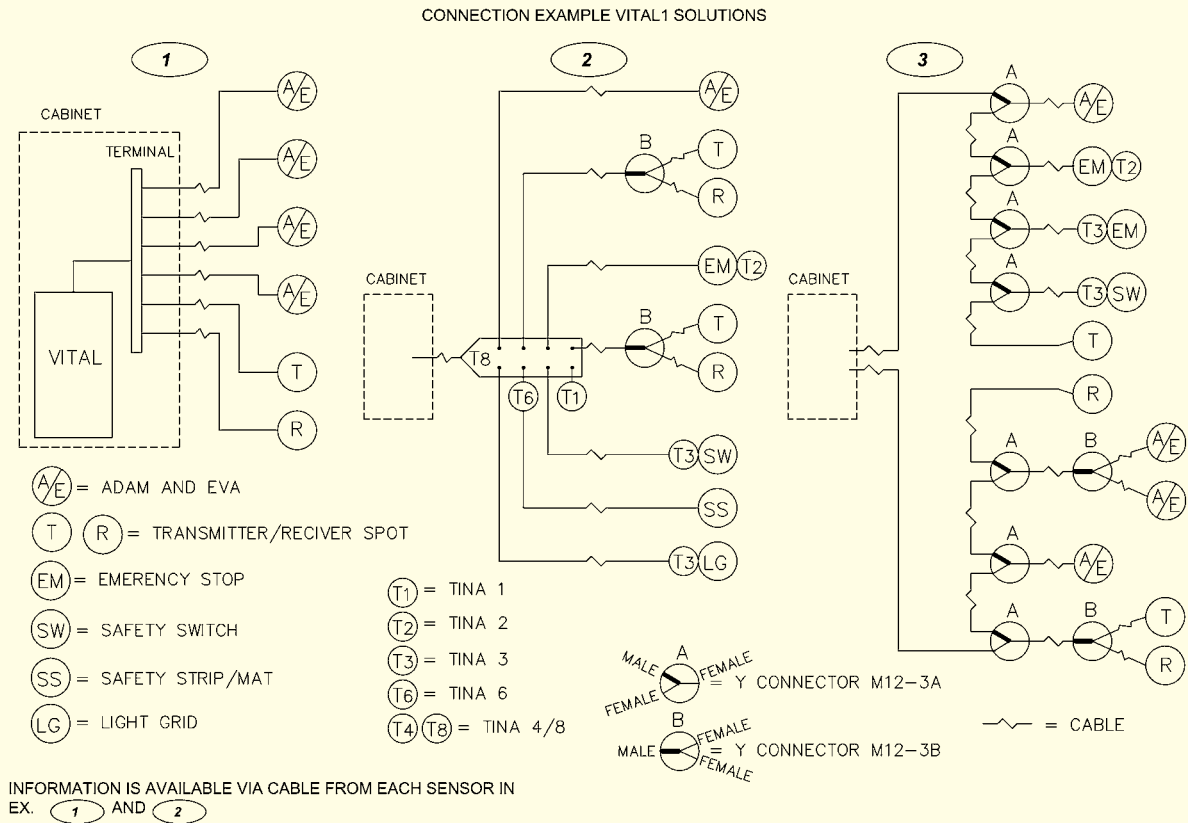

## Cable lengths and number of sensor/adaptor units for the three connection examples.

In order to determine the number of sensor/adaptor units that can be connected to a Vital 1 unit it must be remembered that 1(one) Spot T/R is equivalent to 5(five) Eden or Tina units. Units in parallel are equal to one unit. The following examples provide **guidance** as to possible configurations and cable lengths using suitable cables.

### Example 1

Up to 1000 Metres (0.75mm<sup>2</sup> or 0.34mm<sup>2</sup> conductors) in total can be connected to the sensors/units in this example. The connection is equivalent to 9 Eden or Tina units.

A maximum of 30 Eden or Tina units can be connected to the Vital 1 unit on a maximum cable length of 500 Metres (0.75mm<sup>2</sup> conductors) or 300 Metres (0.34mm<sup>2</sup> conductors).

### Example 2

Up to 600 Metres (0.75mm<sup>2</sup> conductors) to Tina 8A and 10 Metre cables type M12-C1012 (0.34mm<sup>2</sup>) to each sensor/unit connected to the Tina 8A. This connection example is

equivalent to 17 Eden or Tina units.

A maximum of 3 Tina 8A units, equivalent to 27 Eden/Tina units (= 3 x 8 connected to Tina 8A + 3 Tina 8A) can be connected to one Vital 1 with a total cable length of 600 Metres (0.75mm<sup>2</sup>). Up to 6 Tina 4A units can be connected to one Vital 1 (equivalent to 30 Eden/Tina units) with a total cable length of 600 Metres (0.75mm<sup>2</sup>) to Tina 4A.

### Example 3

Either 2 x 500 Metre cables (0.75mm<sup>2</sup>) from the control cabinet and 10 Metre cables (0.34mm<sup>2</sup>) to each sensor/unit or 2 x 10 Metre cables (0.75mm<sup>2</sup>) from the control cabinet and 200 Metre cables (0.75mm<sup>2</sup>) to each sensor/unit. The connection is equivalent to 16 Eden or Tina units.

A Total of 30 Eden/Tina units can be connected using a maximum cable length of 1000 Metres (0.75mm<sup>2</sup>) or 400 Metres (0.34mm<sup>2</sup>). If power supply is only made from one direction (from one end of the network) the total cable length is reduced to approx 300 Metres (0.75mm<sup>2</sup>) and 100 Metres (0.34mm<sup>2</sup>).

# Reset connections – Vital1

## Manual supervised reset

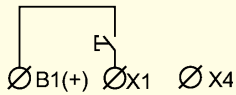

The manual supervised reset contact connected to input X1 must be closed and opened in order to activate the relay outputs.

## Automatic reset

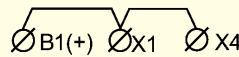

Automatic reset is selected when B1, X1 and X4 are connected. The relay outputs are then activated at the same time as the inputs.

## Testing external contactor status

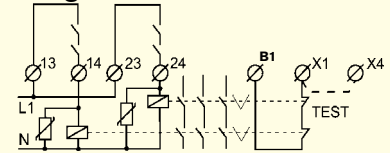

Contactors, relays and valves can be supervised by connecting 'test' contacts between B1 and X1. Both manual supervised and automatic reset can be used.

# Output connection – Vital1

## Relay outputs

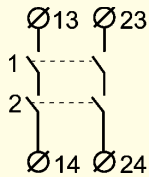

The Vital 1 has two (2 NO) safety outputs. In order to protect the output contacts it is recommended that loads (inductive) are suppressed by fitting correctly chosen VDR's, diodes etc. Diodes are the best arc suppressors, but will increase the switch off time of the load.

## Information outputs

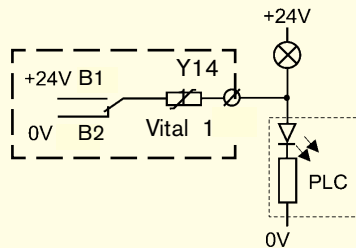

The Vital 1 has a single changeover contact information relay output. The relay output Y14 is connected internally to 0V and 24V in the following way:

- Y14 is internally closed to 0V B2 when the Vital 1 is not reset.
- Y14 is internally closed to +24V B1 when the Vital 1 is reset.

## Connection of S1

Even numbers of sensors (Eden, Spot, Tina) requires a connection between B1 and S1.

S1 is not to be connected for odd numbers of sensors.

See connection examples below fig. A and B.

# Connection examples of safety devices to Vital1

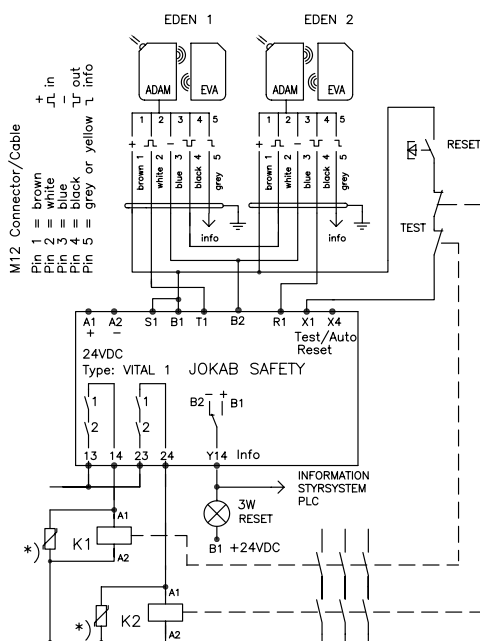

A) EDEN med manuell återställning samt övervakning av yttre kontaktorer/reläer  
EDEN with manual reset and monitoring of external contactors/relays

\*OBS: Använd alltid transient skydd t.ex. VDR!  
\*NOTE: Always use transient suppressors, e.g. VDR's!

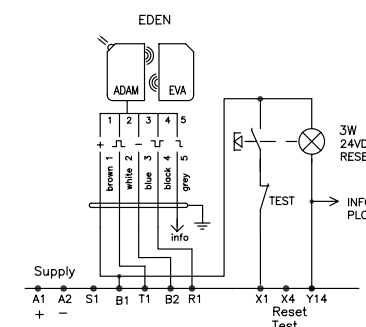

B) EDEN med manuell återställning  
EDEN with manual reset

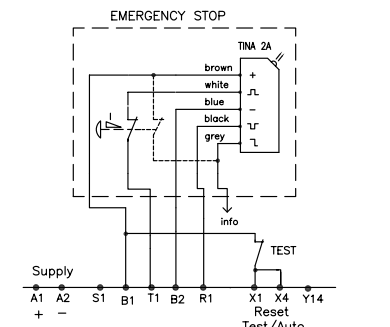

C) Nödstopp med TINA2A och aut. återställning.  
Emergency stop with TINA2A and autom. reset.

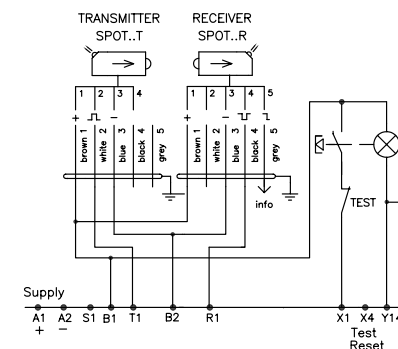

D) Ljusbom SPOT med manuell återställning  
Safety Lightbeam SPOT with manual reset

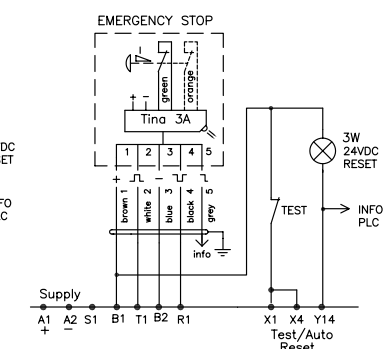

E) Nödstopp med TINA3A och aut. återställning.  
Emergency stop with TINA3A and autom. reset.

## Technical data – Vital1

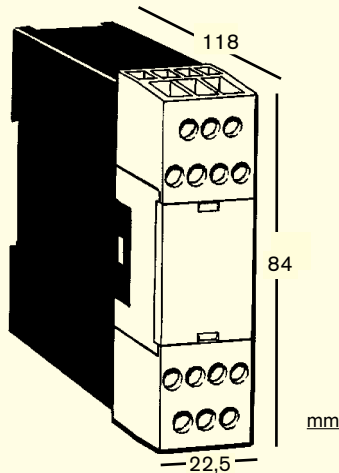

<b>Manufacturer</b>	JOKAB SAFETY AB, Sweden
<b>Ordering data</b>	Vital 1
<b>Safety category (according to EN 954-1)</b>	4
<b>Colour</b>	Black and beige
<b>Weight</b>	220 g

<b>Power supply</b>	
Vital, A1-A2	24 VDC +/- 15%
From Vital to sensors/units, B1-B2	24 VDC

<b>Fuse</b>	
An external fuse should be fitted in supply to A1	3AT

<b>Power consumption</b>	
DC supply, nominal voltage (without load)	3 W
DC supply, nominal voltage (with max load)	48 W

<b>Dynamic safety circuit</b>	
T 1	Output signal
R 1	Input signal

<b>Reset input X1</b>	
Supply for reset input	+24VDC
Reset current	30 mA max. (inrush current 300 mA during contact closure)
Minimum contact closure time for reset	80 ms

**Connection of S1**  
Even numbers of sensors (Eden + Spot T/R + Tina) require a connection between B1 and S1.  
S1 is not connected for odd numbers of sensors.

<b>Number of sensors</b>	
Max. number of Eden/Tina to Vital 1	30
Total max. cable length to Eden/Tina	1000 m
Max. number of Spot T/R to Vital	6 pairs
Total max. cable length to Spot T/R	600 m

The above limits vary depending on cable size and application.  
See connection example in section: Connection of units and cable lengths to Vital 1.

<b>Response time</b>	
At Power on	< 65 ms
When activating (input-output)	< 40 ms
When deactivating (input-output)	< 38 ms
At Power loss	< 45 ms

<b>Relay outputs</b>	
NO	2
Max switching capacity, resistive load	6A/250 VAC/1500 VA/150W
Minimum load	10 mA/10V
Contact material	AgCdO
Mechanical life	>10 <sup>7</sup> operations
External fuse (EN 600947-5-1)	6.3A or 4A slow

<b>Relay information output (changeover contact)</b>	
Y14 - (0V)	Indicates Vital is not reset
+ (24V)	Indicates Vital is reset
Max. load on Y14	200 mA
	(Internal automatic fuse)

<b>LED indication</b>	
On ●	Fixed light: supply voltage OK,
	Flashing light: under-voltage or overload.
T ● R ●	T: Signal out OK. R: Signal in OK.
☒ ● 1 ☒ ● 2	Indicates that the output relays have been activated

<b>Mounting</b>	
DIN rail	35 mm DIN rail
Operating temperature range	-10°C to + 55°C

<b>Connection blocks (detachable)</b>	
Max screw torque	1 Nm
Max connection area:	
Solid conductors	1x4mm <sup>2</sup> /2x1,5mm <sup>2</sup> /12AWG
Conductor with socket contact	1x2,5mm <sup>2</sup> /2x1mm <sup>2</sup>
Air and creep distance	4kV/2 DIN VDE 0110

<b>Protection class</b>	
Enclosure	IP 40 IEC 60529
Connection blocks	IP 20 IEC 60529

**This equipment is intended for (CSA/UL Requirement):**

- indoor use
- altitude max 2000 m
- maximum relative humidity 80% at max 31°C and decreasing linearly to 50% at 40°C.
- pollution degree 2
- installation category (overvoltage category) II: Local level, appliances, portable equipment, etc. with smaller transient Overvoltage than installation category (overvoltage category) III.

This equipment is **not** to be used in **any** other way than stated in technical description.