

# Safety relay JSBT4

## Approvals:

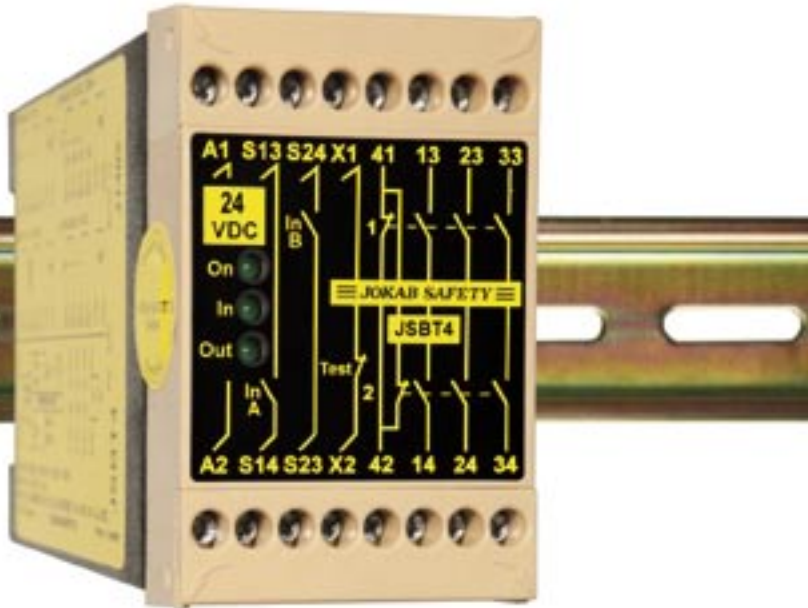

## Safety relay for:

- Emergency stops
- Three position devices
- Interlocked Hatches
- Safety mats
- Contact strips
- Foot operated switches

## Features:

- Dual input channels synchronism 0.5 s
- Test input
- Width 45 mm
- LED indications of power on, inputs and outputs
- 3 NO/1NC relay outputs
- Supply 24 VDC, 24, 48, 115 or 230 VAC
- Quick release connector blocks

### Safety relay with synchronised dual input channels (within 0.5s)

The JSBT4 has two inputs, both of which have to be closed in order to keep the safety output contacts closed. A short circuit between inputs A and B will cause the output contacts to open. The inputs can be continuously short circuit without damaging the safety relay.

For the outputs to close, the test input must be closed. The test input is intended to monitor that contactors or valves have dropped/returned before a new start is permitted.

This test input must not be confused with the reset function required for gates that a person can walk through and where there is a high safety requirement (see JSBR4).

If the JSBT4 is used for safety Mats and safety Strips, the "stop" condition is given following detection of a short circuit. Neither the Safety Mat, Safety Strip or the relay will be damaged by a continuous short circuit. This also provides the advantage that if there is a failure between inputs A and B in the installation, the safety relay will not be damaged.

### Safety level

The JSBT4 has a twin supervised safety function. Neither component failure, short circuit or external disturbance (e.g. loss of power supply) will prevent the safe function of the relay. Category 3 or 4 depending on use.

The true two channel safety function has the advantage that the cabling installation demands for safety can be reduced due to the fact that a short circuit between the inputs will directly open the relays safety outputs.

### Regulations and standards

The JSBT4 is designed and approved in accordance with appropriate standards.

Examples of such are: EN 292-1/2, EN 60204-1, EN 954-1.

### Connection examples

For examples of how our safety relays can solve various safety problems, please see the section "Connection examples".

## Technical data - JSBT4

Manufacturer:	JOKAB SAFETY AB, Sweden
Ordering data:	JSBT4 and supply voltage
Colour:	Black and Beige
Power supply:	24 VDC +/- 15% 24/48/115/230VAC +/- 15%, 50 - 60 Hz
Power consumption:	< 2 VA
Relay outputs:	3 NO + 1 NC
Maximum switching capacity res. load AC:	6A/250 VAC/1500 VA
Maximum switching capacity res. load DC:	6A/24 VDC/150 W
Minimum load:	10mA/10 V (if load on contact has not exceeded 100 mA)
Max. Input Wire res. at nom. voltage:	300 Ohm (S13 - S14 and S23 - S24)
Response time at deactivation:	< 15 ms, 145 ms with switched supply/ power loss
Terminals (Max. screw torque 1 Nm):	Single strand: 1x4 mm <sup>2</sup> /2x1,5 mm <sup>2</sup> Conductor with socket contact: 1x2,5 mm <sup>2</sup> /2x1 mm <sup>2</sup> .
Mounting:	35 mm DIN-rail
Protection class enclosure/terminals:	IP 40/20 IEC 60529
Operating temperature range:	-10°C – +55°C
Air and creep distance:	4kV/2 IEC 60664-1
Function indication:	Electrical Supply, Inputs, Outputs
Weight:	350 g (24VDC), 460 g (24-230VAC)

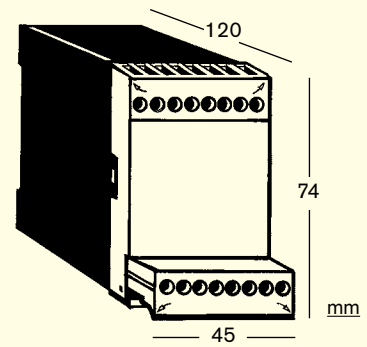

## Technical description - JSBT4

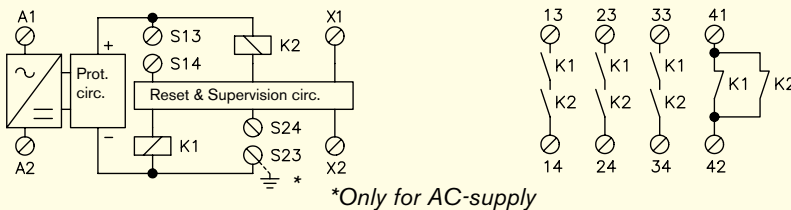

The electrical supply is connected across A1 and A2. After Voltage reduction and Rectification (AC-versions) or reverse polarity protection (DC-version) there is an overload protection-circuit.

When the inputs S13-S14 and S23-S24 are closed within 0.5 seconds of each other the relays K1 and K2 are energized. A dual stop signal is given, K1 and K2 de-energize, when there is a short circuit between or an opening of the inputs and at power loss. If

one input is opened the other one also has to be opened in order to activate K1 and K2 again. The test circuit, X1 - X2, has to be closed in order to activate the outputs, thereafter the test circuit can be opened or closed continuously. If the test circuit is closed after the inputs there is no requirement to close them within 0.5 seconds of each other.

The internal supervision circuit monitors the two Inputs and relays K1, K2. The stop function then fulfils the requirement that one

failure (short circuit, component, external disturbance) shall not prevent the safe function of the JSBT4.

The safety outputs consist of contacts from K1 and K2 connected internally in series across terminals 13 - 14, 23 - 24 and 33 - 34. These contacts are used to cut the power to components which stop or prevent hazardous movements/functions. It is recommended that all switched loads are adequately suppressed and/or fused in order to provide additional protection for the safety contacts.

The NC output 41 - 42 should only be used for monitoring purpose e.g. Indication lamp or PLC input etc. The output contacts are closed until the module is reset.

**Note:** Output 41-42 is intended for indication purposes only, e.g. gate opened. No load between S14 and S24 allowed.

## Electrical connection - JSBT4

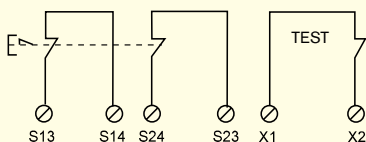

Emergency stop with automatic resetting.

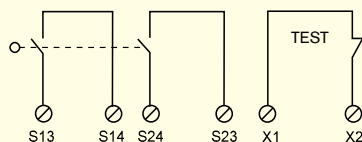

Interlocked hatch with automatic resetting.

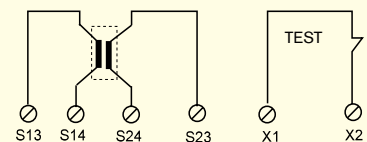

Contact mat/strip with automatic reset

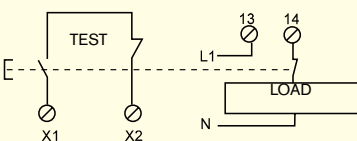

Monitoring to ensure that the Start button cannot stick in pressed position. Short circuiting over the closing contact is not monitored. The RT-series and JSBR4 have built in short circuiting monitored resetting.

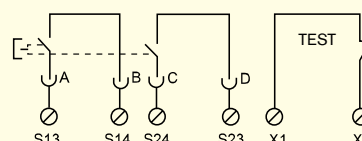

Enabling device, JSHD4. Stop condition is given in both top and bottom positions.

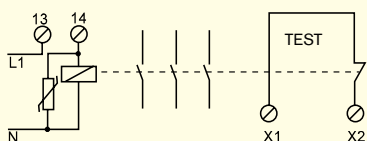

Control and supervision of external contactor, relay, valve or JOKAB SAFETY's expansion relays.