

Wire Ø 3 mm

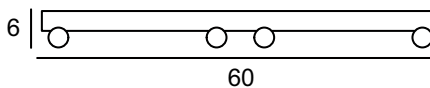

	Length mm	Electro-galv. Part No	Weight kg	Hot dip galv. Part No	Weight kg	Stainl. steel AISI316L Part No	Weight kg
Mini Mesh B30-I	2000	11 491 11	0,50	11 492 11	0,55	11 493 11	0,52

Use and installation

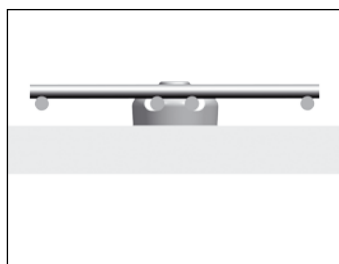

B30-I mounted onto Mounting spacer B22.



B30-I mounted onto cable ladder.

Fitting B1

Delivered without bolt and nut.

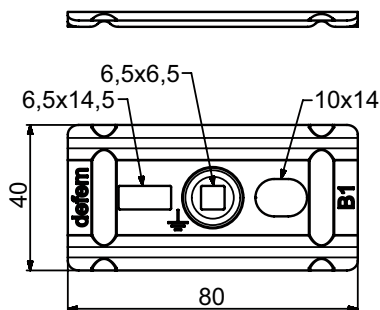

	Electro-galv. Part No	Weight kg	Hot dip galv. Part No	Weight kg	Stainl. steel AISI316L Part No	Weight kg
Fitting B1	11 491 54	0,06	11 492 54	0,07	11 493 54	0,06

Use and installation

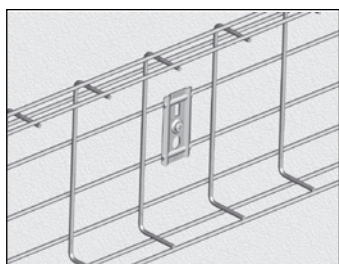

Fitting B1 can be used as a wall bracket.

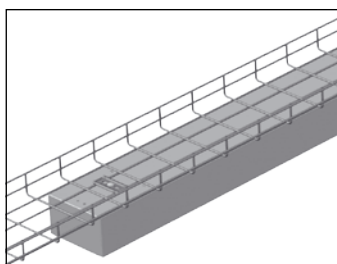

Fitting B1 can be mounted over the centre wires as carrier of lighting fittings.

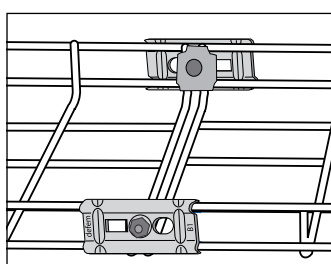

Wire tray 53 to 220 is joined with:
2 pcs of Fitting B1
2 pcs of Fitting B2
2 pcs of Bolt and Nut B13